

DATA SHEET

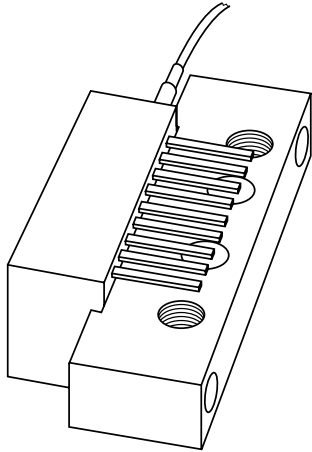

CGO869 870 MHz optical receiver with integrated gain control

Product specification
Supersedes data of 2002 Dec 10

2003 Oct 22

870 MHz optical receiver with integrated gain control

CGO869

FEATURES

- Excellent linearity
- Extremely low noise up to 870 MHz
- Excellent flatness (straight line)
- Standard CATV outline
- Rugged construction
- Gold metallization ensures excellent reliability.

APPLICATIONS

- CATV systems operating in the 40 to 870 MHz frequency range.

DESCRIPTION

Hybrid high dynamic range optical receiver amplifier module in a SOT115AD package where the non-jacketed fibre has no connector. Two of the module pins are for connection to 24 V (DC), one for amplifier supply voltage and the other for the photodiode bias.

The module contains a monomode optical input suitable for wavelengths from 1290 to 1600 nm, a terminal to monitor the photodiode current and an electrical output with an impedance of 75 Ω. The gain of the amplifier can be adjusted with one module pin.

PINNING

PIN	DESCRIPTION
1	monitor current
2, 3	common
4	+V _B of the photo diode
5	+V _B of the amplifier
6	V _C (gain control)
7, 8	common
9	output

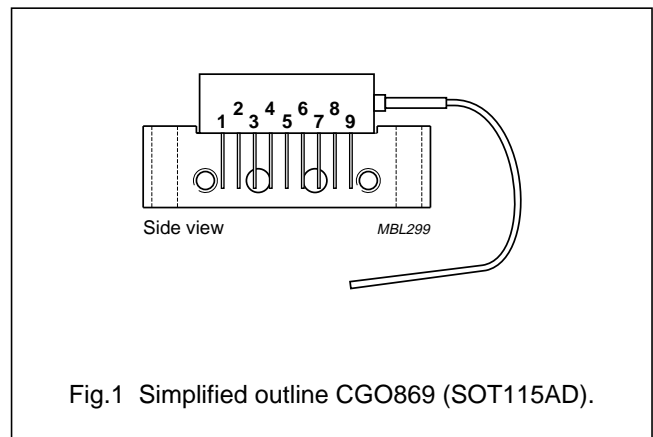

Fig.1 Simplified outline CGO869 (SOT115AD).

QUICK REFERENCE DATA

SYMBOL	PARAMETER	CONDITIONS	MIN.	MAX.	UNIT
f	frequency range		40	870	MHz
S ₂₂	output return losses	f = 40 to 870 MHz	16	–	dB
	optical input return losses		40	–	dB
d ₂	second order distortion	f = 854.5 MHz	–	–61	dB
F	equivalent input noise	f = 40 MHz	–	5	pA/√Hz
I _{tot}	total current consumption (DC)	V _B = 24 V	175	205	mA

CAUTION

This product is supplied in anti-static packing to prevent damage caused by electrostatic discharge during transport and handling. For further information, refer to Philips specs.: SNW-EQ-608, SNW-FQ-302A and SNW-FQ-302B.

870 MHz optical receiver with integrated gain control

CGO869

HANDLING

Fibreglass optical coupling: maximum tensile strength = 5 N; minimum bending radius = 35 mm.

ORDERING INFORMATION

TYPE NUMBER	PACKAGE		
	NAME	DESCRIPTION	VERSION
CGO869	–	rectangular single-ended package; aluminium flange; 2 vertical mounting holes; 2 x 6-32 UNC and 2 extra horizontal mounting holes; optical input; 9 gold-plated in-line leads	SOT115AD

LIMITING VALUES

In accordance with the Absolute Maximum Rating System (IEC 60134).

SYMBOL	PARAMETER	CONDITIONS	MIN.	MAX.	UNIT
f	frequency range		40	870	MHz
T _{stg}	storage temperature		–40	+85	°C
T _{mb}	operating mounting base temperature		–20	+85	°C
P _{in}	optical input power	continuous	–	5	mW
ESD	ESD sensitivity	human body model; R = 1.5 kΩ; C = 100 pF	500	–	V

CHARACTERISTICS

Bandwidth 40 to 870 MHz; V_B = 24 V; T_{mb} = 35 °C; Z_L = 75 Ω; gain control V_C = 0 V.

SYMBOL	PARAMETER	CONDITIONS	MIN.	MAX.	UNIT
S	responsivity	λ = 1550 nm	2000	–	V/W
FL	flatness straight line	peak to valley; f = 40 to 870 MHz	–	1.1	dB
SL	slope straight line	f = 40 to 870 MHz	0	2	dB
s ₂₂	output return losses	f = 40 to 870 MHz	16	–	dB
	optical input return losses		40	–	dB
d ₂	second order distortion	f _m = 54 MHz; notes 1 and 3	–	–74	dB
		f _m = 446.5 MHz; notes 1 and 4	–	–66	dB
		f _m = 548.5 MHz; notes 1 and 5	–	–66	dB
		f _m = 746.5 MHz; notes 1 and 6	–	–64	dB
		f _m = 854.5 MHz; notes 1 and 7	–	–61	dB
d ₃	third order distortion	f _m = 55.25 MHz; notes 2 and 8	–	–76	dB
		f _m = 445.25 MHz; notes 2 and 9	–	–74	dB
		f _m = 547.25 MHz; notes 2 and 10	–	–73	dB
		f _m = 745.25 MHz; notes 2 and 11	–	–73	dB
		f _m = 853.25 MHz; notes 2 and 12	–	–69	dB
F	equivalent input noise	f = 40 to 750 MHz	–	5.5	pA/√Hz
		f = 750 to 870 MHz	–	6.5	pA/√Hz

870 MHz optical receiver with integrated gain control

CGO869

SYMBOL	PARAMETER	CONDITIONS	MIN.	MAX.	UNIT
s_λ	spectral sensitivity	$\lambda = 1310 \pm 20 \text{ nm}$	0.85	–	A/W
		$\lambda = 1550 \pm 20 \text{ nm}$	0.9	–	A/W
λ	optical wavelength		1290	1600	nm
L	length of optical fibre	fibre; SM type; 9/125 μm	1	–	m
I_{tot}	total current consumption (DC)		175	205	mA
I_{bias}	diode bias current at pin4 (DC)		–	25	mA

Notes

- Two laser test; each laser with 40% modulation index; $P_{\text{opt}} = 0.5 \text{ mW}$ (total).
- Three laser test; each laser with 60% modulation index; $P_{\text{opt}} = 0.5 \text{ mW}$ (total).
- $f_m = 54 \text{ MHz}$; $f_p = 187.25 \text{ MHz}$; $f_q = 133.25 \text{ MHz}$.
- $f_m = 446.5 \text{ MHz}$; $f_p = 97.25 \text{ MHz}$; $f_q = 349.25 \text{ MHz}$.
- $f_m = 548.5 \text{ MHz}$; $f_p = 109.25 \text{ MHz}$; $f_q = 439.25 \text{ MHz}$.
- $f_m = 746.5 \text{ MHz}$; $f_p = 133.25 \text{ MHz}$; $f_q = 613.25 \text{ MHz}$.
- $f_m = 854.5 \text{ MHz}$; $f_p = 133.25 \text{ MHz}$; $f_q = 721.25 \text{ MHz}$.
- $f_m = 55.25 \text{ MHz}$; $f_p = 109.25 \text{ MHz}$; $f_q = 133.25 \text{ MHz}$; $f_r = 187.25 \text{ MHz}$.
- $f_m = 445.25 \text{ MHz}$; $f_p = 193.25 \text{ MHz}$; $f_q = 349.25 \text{ MHz}$; $f_r = 97.25 \text{ MHz}$.
- $f_m = 547.25 \text{ MHz}$; $f_p = 217.25 \text{ MHz}$; $f_q = 439.25 \text{ MHz}$; $f_r = 109.25 \text{ MHz}$.
- $f_m = 745.25 \text{ MHz}$; $f_p = 133.25 \text{ MHz}$; $f_q = 265.25 \text{ MHz}$; $f_r = 613.25 \text{ MHz}$.
- $f_m = 853.25 \text{ MHz}$; $f_p = 133.25 \text{ MHz}$; $f_q = 265.25 \text{ MHz}$; $f_r = 721.25 \text{ MHz}$.

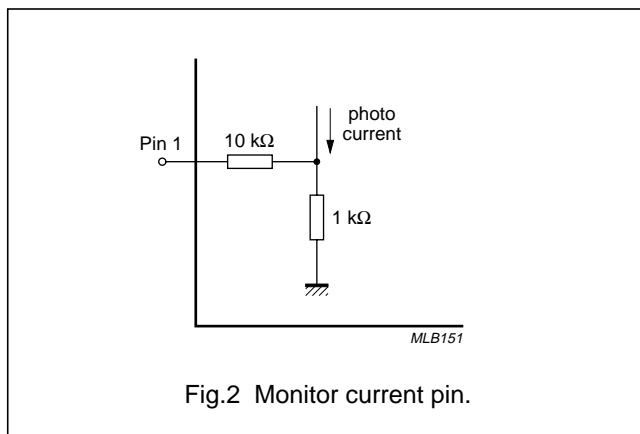

870 MHz optical receiver with integrated gain control

CGO869

Gain control

Bandwidth 40 to 870 MHz; $V_B = 24$ V; $T_{mb} = 35$ °C; $Z_L = 75$ Ω .

SYMBOL	PARAMETER	CONDITIONS	MIN.	TYP.	MAX.	UNIT
S	responsivity	$V_C = 0$ V; $f = 40$ MHz	2000	–	–	V/W
		$V_C = 24$ V; $f = 40$ MHz	900	–	–	V/W
G_V	electric gain control range		–	6.5	–	dB
$P_{in} = 0.5$ mW; $V_C = 0$ V						
V_o	output voltage	OMI = 4%; $f = 870$ MHz	29	–	–	dBmV
F	equivalent input noise	$f = 870$ MHz	–	–	6.5	pA/ $\sqrt{\text{Hz}}$
CNR	carrier to noise ratio	OMI = 4%; RIN = –155 dB/Hz; $I_{PD} = 0.425$ mA; BW = 5 MHz	50.9	–	–	dB
$P_{in} = 0.75$ mW; $V_C = 12$ V						
V_o	output voltage	OMI = 4%; $f = 870$ MHz	29	–	–	dBmV
F	equivalent input noise	$f = 870$ MHz	–	–	12	pA/ $\sqrt{\text{Hz}}$
CNR	carrier to noise ratio	OMI = 4%; RIN = –155 dB/Hz; $I_{PD} = 0.6$ mA; BW = 5 MHz	51.1	–	–	dB
$P_{in} = 1$ mW; $V_C = 24$ V						
V_o	output voltage	OMI = 4%; $f = 870$ MHz	29	–	–	dBmV
F	equivalent input noise	$f = 870$ MHz	–	–	17	pA/ $\sqrt{\text{Hz}}$
CNR	carrier to noise ratio	OMI = 4%; RIN = –155 dB/Hz; $I_{PD} = 0.85$ mA; BW = 5 MHz	51.7	–	–	dB
$P_{in} = 0.5$ to 1 mW						
d_2	second order distortion	OMI = 40%; $f_m = 854.5$ MHz; V_C adjusted to $V_{out} = 49$ dBmV	–	–	–61	dB
d_3	third order distortion	OMI = 60%; $f_m = 853.25$ MHz; V_C adjusted to $V_{out} = 49$ dBmV	–	–	–69	dB

870 MHz optical receiver with integrated gain control

CGO869

PACKAGE OUTLINE

Rectangular single-ended package; aluminium flange; 2 vertical mounting holes;
2 x 6-32 UNC and 2 extra horizontal mounting holes; optical input; 9 gold-plated in-line leads

SOT115AD

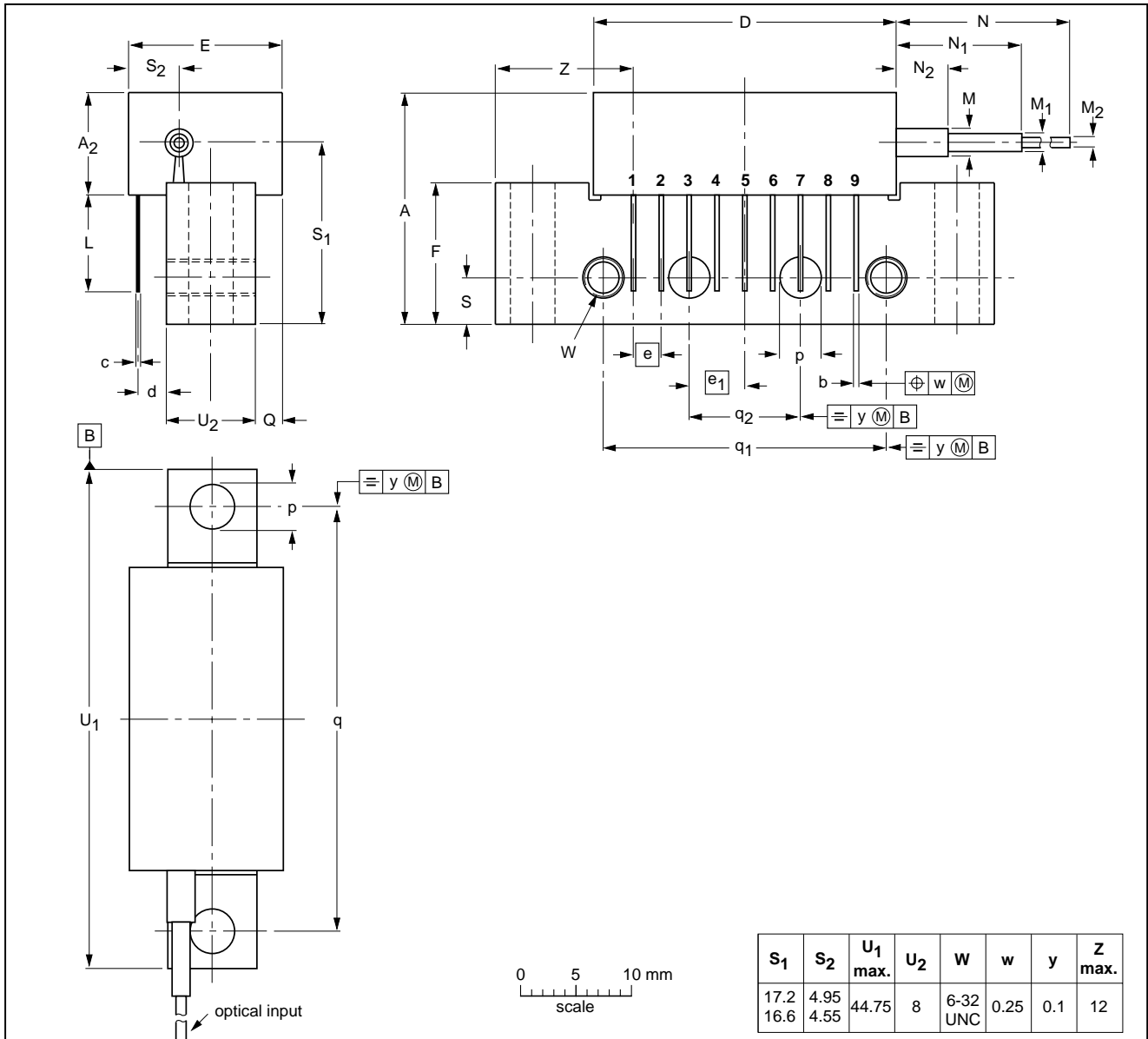

DIMENSIONS (mm are the original dimensions)

UNIT	A max.	A ₂ max.	b	c	D max.	d max.	E max.	e	e ₁	F	L min.	M	M ₁	M ₂	N min.	N ₁	N ₂	p	Q max.	q	q ₁	q ₂	S
mm	20.8	9.1	0.51 0.38	0.25	27.2	2.54	13.75	2.54	5.08	12.7	8.8	2.5	1.6	0.9	1000	10.7 0.0	5 0	4.15 3.85	2.4	38.1	25.4	10.2	4.2

OUTLINE VERSION	REFERENCES				EUROPEAN PROJECTION	ISSUE DATE
	IEC	JEDEC	JEITA			
SOT115AD						02-03-13 03-06-20

870 MHz optical receiver with integrated gain control

CGO869

DATA SHEET STATUS

LEVEL	DATA SHEET STATUS ⁽¹⁾	PRODUCT STATUS ⁽²⁾⁽³⁾	DEFINITION
I	Objective data	Development	This data sheet contains data from the objective specification for product development. Philips Semiconductors reserves the right to change the specification in any manner without notice.
II	Preliminary data	Qualification	This data sheet contains data from the preliminary specification. Supplementary data will be published at a later date. Philips Semiconductors reserves the right to change the specification without notice, in order to improve the design and supply the best possible product.
III	Product data	Production	This data sheet contains data from the product specification. Philips Semiconductors reserves the right to make changes at any time in order to improve the design, manufacturing and supply. Relevant changes will be communicated via a Customer Product/Process Change Notification (CPCN).

Notes

1. Please consult the most recently issued data sheet before initiating or completing a design.
2. The product status of the device(s) described in this data sheet may have changed since this data sheet was published. The latest information is available on the Internet at URL <http://www.semiconductors.philips.com>.
3. For data sheets describing multiple type numbers, the highest-level product status determines the data sheet status.

DEFINITIONS

Short-form specification — The data in a short-form specification is extracted from a full data sheet with the same type number and title. For detailed information see the relevant data sheet or data handbook.

Limiting values definition — Limiting values given are in accordance with the Absolute Maximum Rating System (IEC 60134). Stress above one or more of the limiting values may cause permanent damage to the device. These are stress ratings only and operation of the device at these or at any other conditions above those given in the Characteristics sections of the specification is not implied. Exposure to limiting values for extended periods may affect device reliability.

Application information — Applications that are described herein for any of these products are for illustrative purposes only. Philips Semiconductors make no representation or warranty that such applications will be suitable for the specified use without further testing or modification.

DISCLAIMERS

Life support applications — These products are not designed for use in life support appliances, devices, or systems where malfunction of these products can reasonably be expected to result in personal injury. Philips Semiconductors customers using or selling these products for use in such applications do so at their own risk and agree to fully indemnify Philips Semiconductors for any damages resulting from such application.

Right to make changes — Philips Semiconductors reserves the right to make changes in the products - including circuits, standard cells, and/or software - described or contained herein in order to improve design and/or performance. When the product is in full production (status 'Production'), relevant changes will be communicated via a Customer Product/Process Change Notification (CPCN). Philips Semiconductors assumes no responsibility or liability for the use of any of these products, conveys no licence or title under any patent, copyright, or mask work right to these products, and makes no representations or warranties that these products are free from patent, copyright, or mask work right infringement, unless otherwise specified.

Philips Semiconductors – a worldwide company

Contact information

For additional information please visit <http://www.semiconductors.philips.com>. Fax: +31 40 27 24825

For sales offices addresses send e-mail to: sales.addresses@www.semiconductors.philips.com.

© Koninklijke Philips Electronics N.V. 2003

SCA75

All rights are reserved. Reproduction in whole or in part is prohibited without the prior written consent of the copyright owner.

The information presented in this document does not form part of any quotation or contract, is believed to be accurate and reliable and may be changed without notice. No liability will be accepted by the publisher for any consequence of its use. Publication thereof does not convey nor imply any license under patent- or other industrial or intellectual property rights.

Printed in The Netherlands

R77/07/pp8

Date of release: 2003 Oct 22

Document order number: 9397 750 11914

Let's make things better.

**Philips
Semiconductors**



PHILIPS